

Assembly Instructions

For Hutch

Model shown is example only. Styles may vary

Furniture Care Instructions

Room Climate Control

Wood, when first cut contains more than 50 percent water. When it is prepared for furniture construction it is placed in a Kiln and the moisture content is brought down to 8 to 10 percent. Wood is porous and responds to its environment. If the room has high humidity it will absorb it and expand and if the humidity is low it will lose moisture and shrink.

It is important that the humidity levels in the room be controlled from extremes of too much humidity or too little. Furniture should not be placed close to air-conditioning outlets, fire places, radiators, space heaters, humidifiers or dehumidifiers. Exposure to extreme variations of temperature and humidity can damage any fine wood product.

The Ideal Environment for Fine Furniture

Fine wood furniture will have fewer problems when its environment is controlled at a temperature between 65 and 75 degrees and a relative humidity between 35 and 40 percent. Wood placed in an environment outside of those limits can and will shrink or expand and may develop some small cracks which are not material or structural defects.

Sticking Doors and Drawers

With the minor changes in temperature and humidity doors and drawers may swell and be difficult to open or close. Tolerances have been built into the units but extreme conditions may still cause sticking. This will adjust back to normal over time but until it does consider using a dehumidifier or rub candle wax or paraffin on the sides that stick.

Avoid Direct Sunlight

Keep the furniture out of direct sunlight. Ultraviolet rays will fade colors and in some cases darken them. It can also cause crazing or hair line cracks in the finish. White finishes will yellow naturally over time and exposure to direct sunlight will hasten this natural process along with some woods darkening naturally over time; this is not considered to be a quality defect.

Proper Storage

If you need to put your furniture in storage for any period of time do not store them in a damp basement or hot dry attic. Allow air movement around the furniture and do not stack anything on it.

In General

- Protect furniture surface from hot or extremely cold items.
- Use coasters under hot or cold beverages
- Do not use synthetic fabric under accessories or lamps
- Protect tops from pens, markers and crayons
- Oils from potpourri and other scented items can damage the furniture finish.
- Do not drag items across the surface of the furniture.
- Allow the surface to breath by rotating your accessories and lamps.
- Do not over polish the furniture, do it only two or three times a year. Over polishing can distort the natural finish of the product.
- Do not wax the furniture as wax build up can destroy the natural finish of the product.
- When moving furniture always lift the unit. Do not push or drag it to avoid damage to legs
- Keep the furniture level so doors and drawers open and close freely.
- Clean with a damp, not wet, cloth. Use only a mild soap. Do not use abrasive cleaners.

STOP

**IF YOU EXPERIENCE ANY
ISSUES WITH THIS PRODUCT**

**BEFORE YOU
RETURN THIS TO
THE RETAILER**

**PLEASE FOLLOW
PROCEDURES ON THE
REVERSE SIDE OF THIS FORM.**

Product Assistance Procedures

You have purchased a quality piece of furniture. Our international team has spent many hours designing and engineering this piece and packaging to ensure you will be satisfied with your purchase. But if for any reason you need help with your purchase please contact us at any time.

Procedures to follow should you have any questions:

For best and most timely service please contact us by e-mail at info@lajobi.com

Please provide the following information in your e-mail.

1. Your Name _____
2. Address _____

3. Phone number _____
4. Place and date of purchase _____

5. Item number and description of your product. _____

The item number can be found on the back of the case or on the foot/headboard of the crib. Please include all numbers found on that label including the PO# and production date.

6. Short description of the issues and attach a photo if possible.

Someone will contact you via e-mail or phone to help you with your issues.

If you do not have internet access, please fax the above information to 609-409-5809

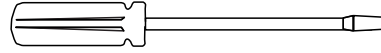
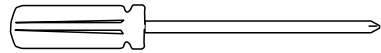
If you do not have internet or fax access, please call us at 888-266-2848 and be sure to have all the above information ready to give to your Client Service Specialist.

Thank you for choosing a Bonavita Product. To ensure the best performance from your hutch, please read the following instructions carefully.

Carefully remove and lay out all parts. Familiarize yourself with all exhibits and diagrams to facilitate the assembly of your hutch

Please call Lajobi with any comments or questions, Do not return to retailer.

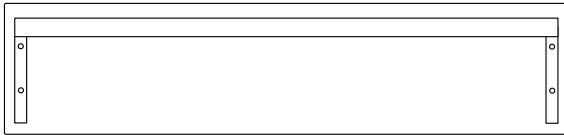
TOOLS REQUIRED: Philips head and slotted screwdriver



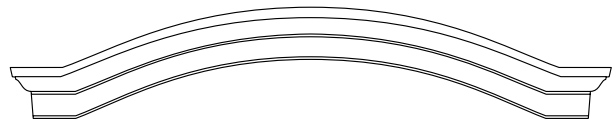
PARTS ENCLOSED IN CARTON

Model shown is example only. Styles may vary

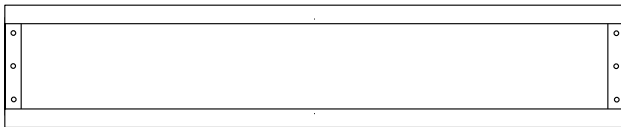
A (1) Top



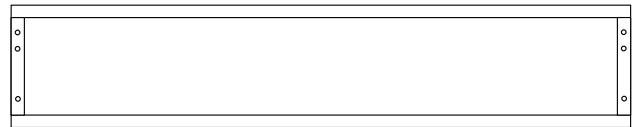
B (1) Top Molding



C (1) Fixed Shelf



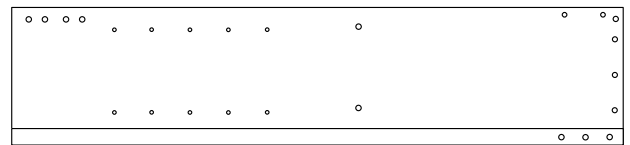
D (1) Adjustable shelf



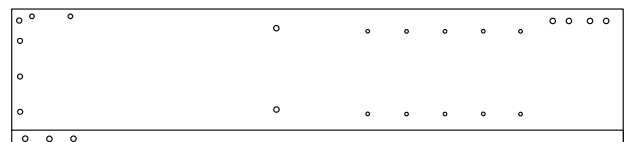
E (1) Bottom Rail



F (2) Side Panel

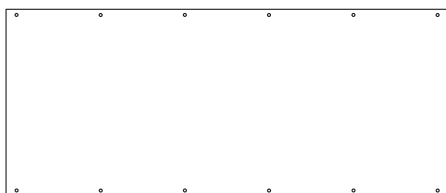


Right



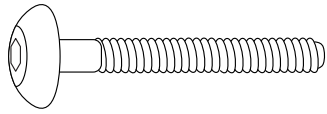
Left

G (2) Back Panel

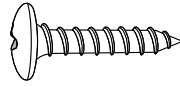


PARTS ENCLOSED IN HARDWARE BAG

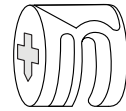
H (15) Allen head Bolt 1-3/8"



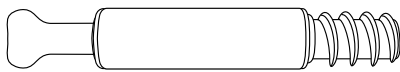
I (26) Wood Screw 3/4"



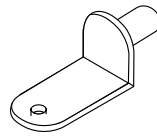
J (4) Cam Lock



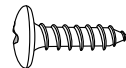
K (4) Cam Rods



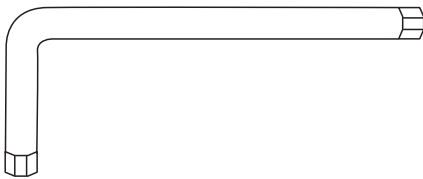
L (4) Shelf Pegs



M (4) Philips head screws 1/2"

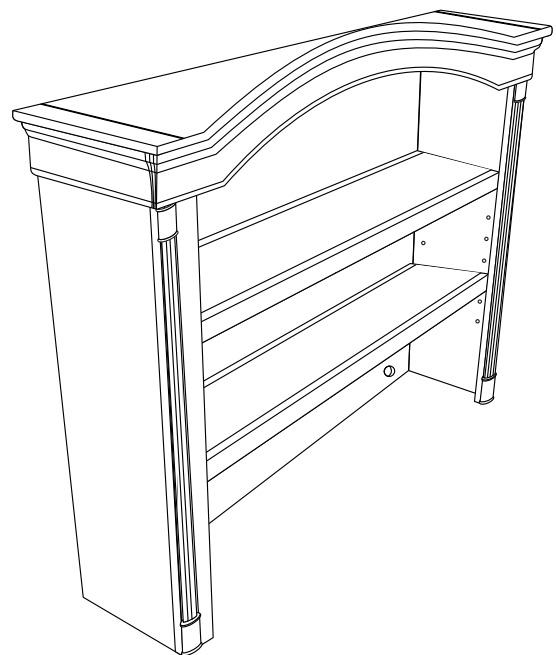


N (1) Allen wrench



CARE & MAINTENANCE

WHEN CLEANING YOUR HUTCH, USE A NON-TOXIC, NON ABRASIVE CLEANER. MIX A SOLUTION OF WATER WITH A SMALL AMOUNT OF A MILD DISHWASHING LIQUID. APPLY TO THE HUTCH SURFACE WITH A SOFT DAMP CLOTH LIGHTLY DAMPENED IN SOLUTION. AFTER CLEANING, DRY COMPLETELY WITH A SOFT DRY CLOTH.



STEP 1 Inserting the Cam Rods

THIS STEP REQUIRES:

RIGHT SIDE PANEL (F)

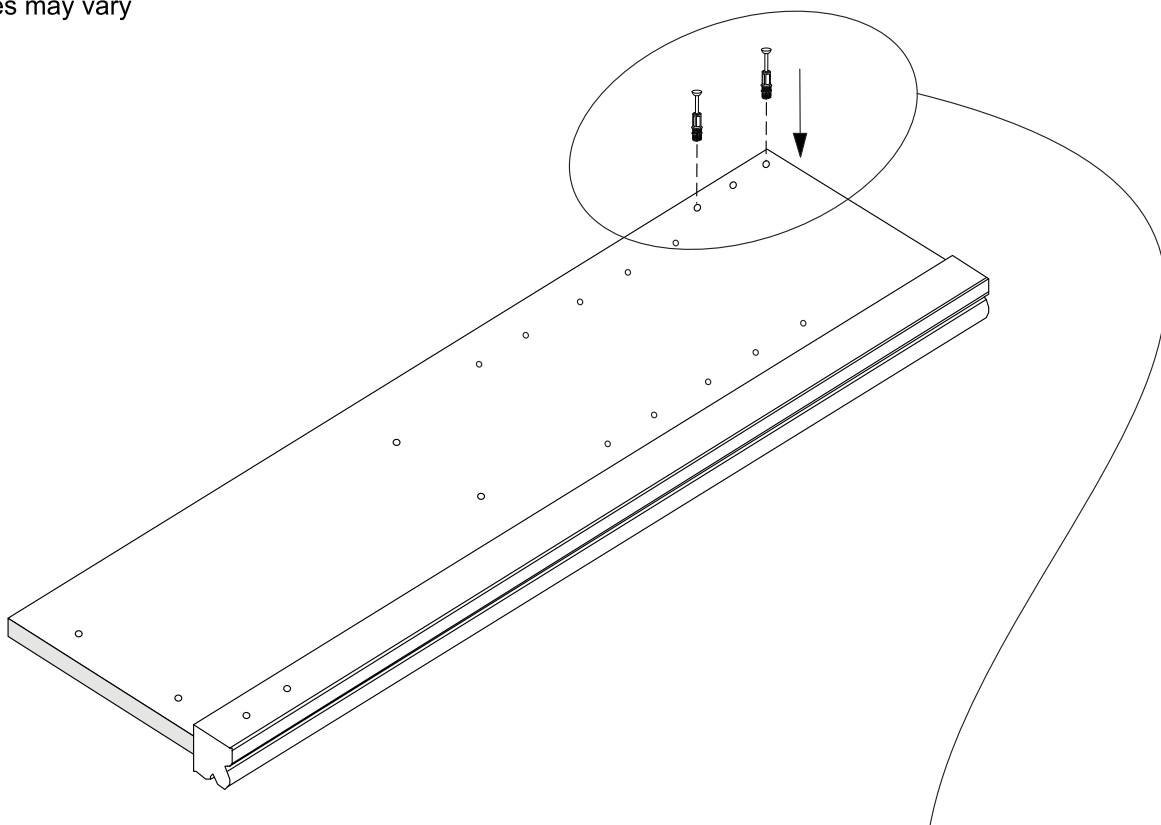
LEFT SIDE PANEL (F)

(4) Cam Rods (K)

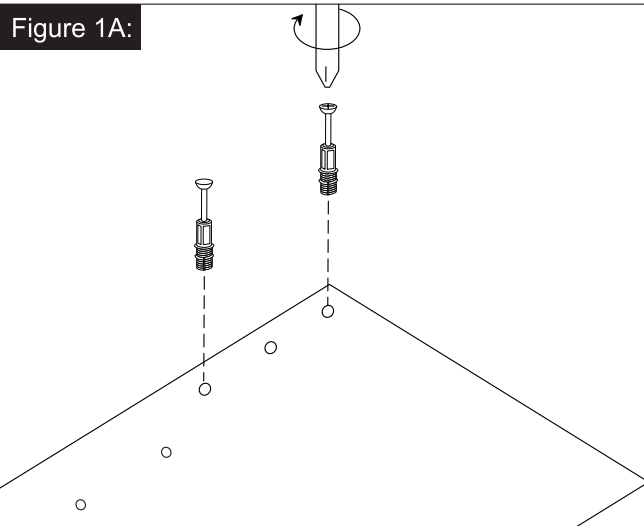


Figure 1:

Model shown is example only.
Styles may vary

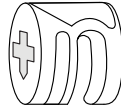


- A.** Insert the Cam Rods into the inset nut into the Left Side as shown Figure 1, Tighten with the Philips screwdriver as shown Figure 1A. Repeat on the Right Side.



STEP 2 Assembly of Bottom Rail

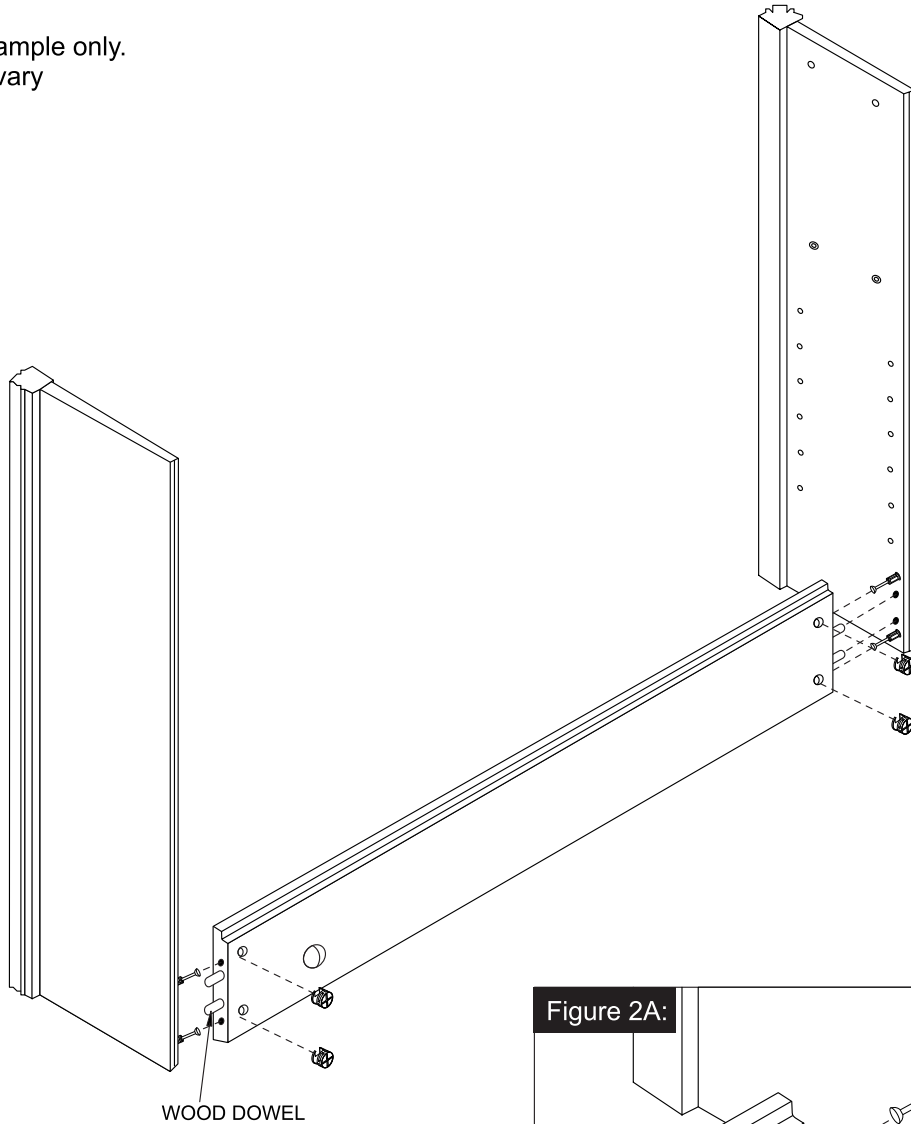
THIS STEP REQUIRES:
BOTTOM RAIL (E)



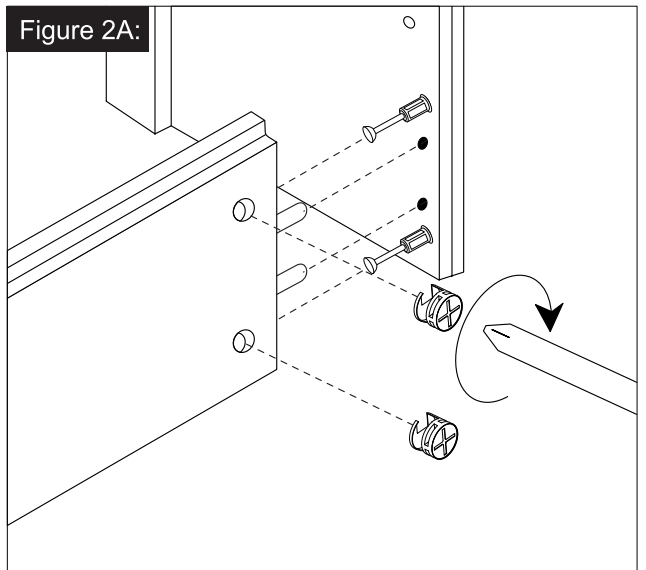
(4) Cam Locks (J)

Figure 2:

Model shown is example only.
Styles may vary



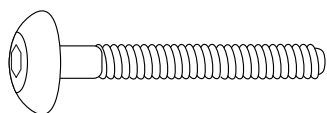
- A.** Align the Cam Rods into the holes of the bottom rail as shown Figure 2
- B.** Insert the Cam Locks and align the gaps with the Cam Rods, then rotate the Cam Locks in clock-wise direction with a Philips screwdriver to lock the Cam Rods.



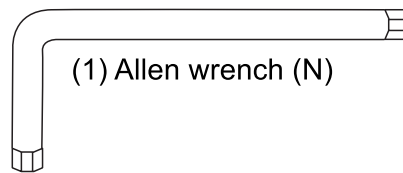
STEP 3 Assembly of the Fixed Shelf

THIS STEP REQUIRES:

FIXED SHELF (C)



(4) Allen head Bolt 1-3/8" (H)



(1) Allen wrench (N)

Figure 3:

Attach the Fixed Shelf to the Side Panels using 4 Allen head bolts. Insert the 1-3/8" Allen head bolts first through inside edge of the Fixed Shelf, then through the threaded inserts in the Side Panels (Fig.3 & 3A), Tighten with Allen wrench.

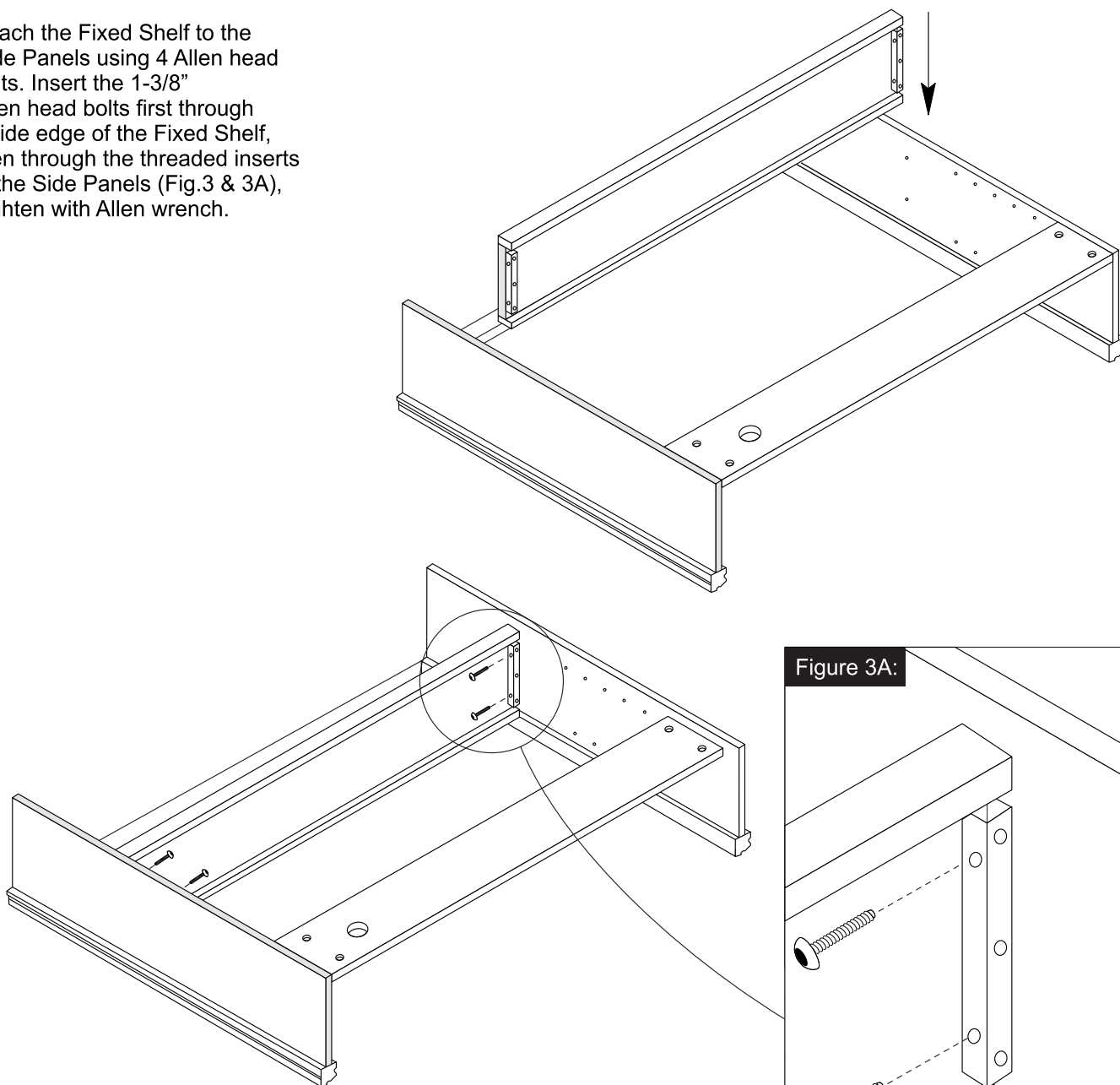
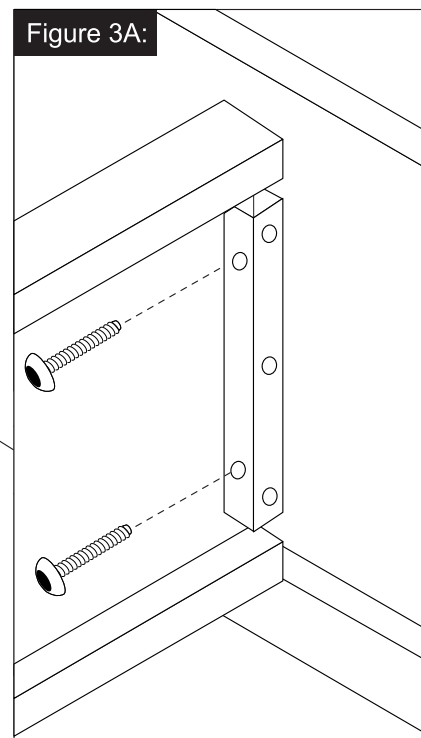


Figure 3A:

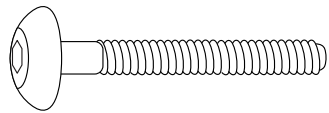


Model shown is example only.
Styles may vary

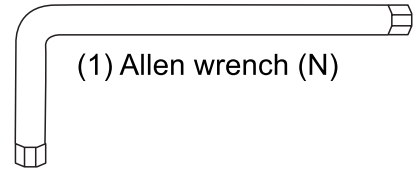
STEP 4 Assembly of Top

THIS STEP REQUIRES:

TOP (A)



(4) Allen head Bolt 1-3/8" (H)



(1) Allen wrench (N)

Figure 4:

Model shown is example only.
Styles may vary

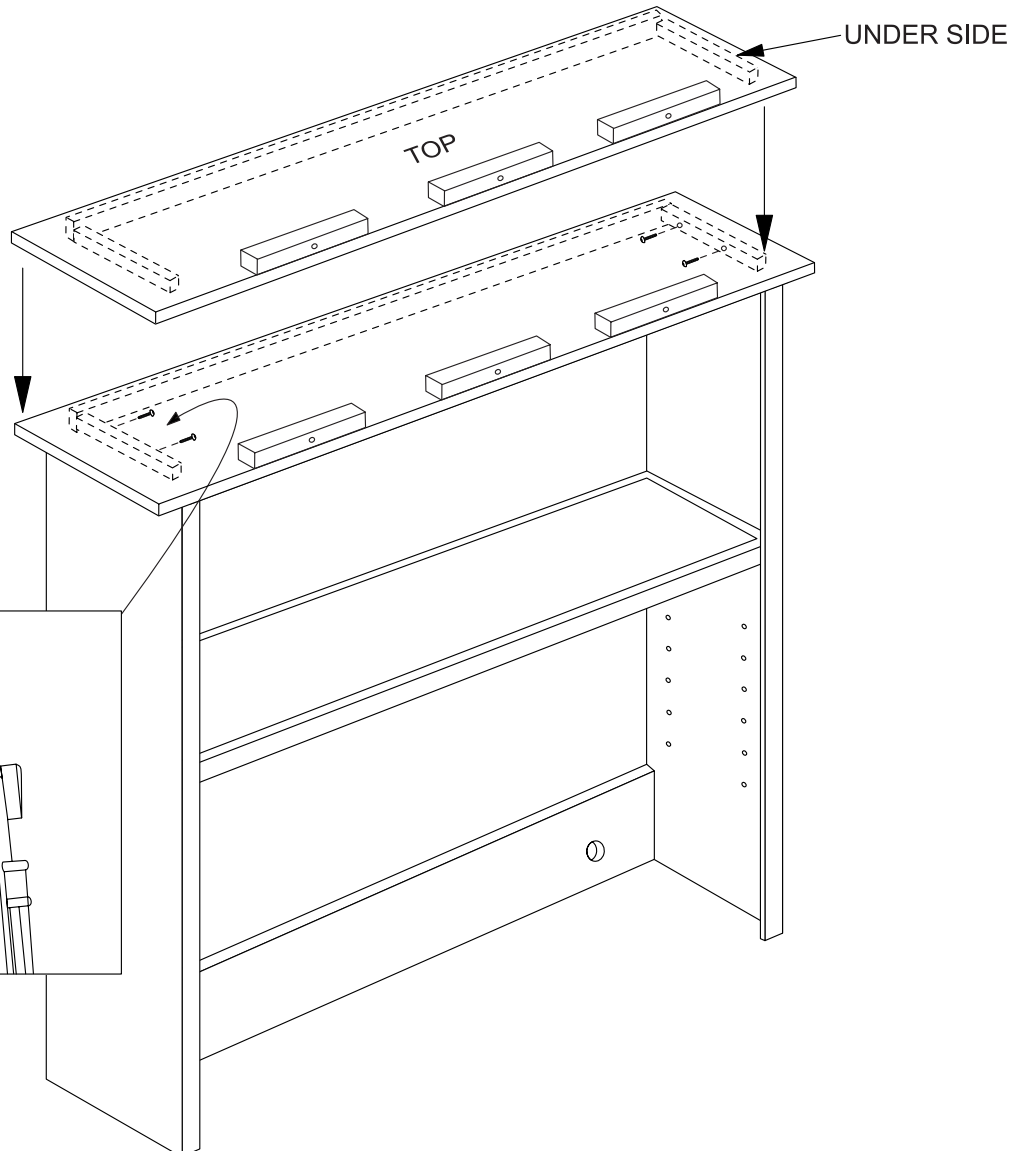
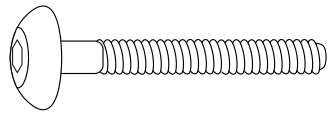


Figure 4A:

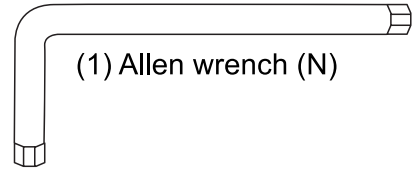
- A.** Attach the Top to the Side Panels using the 4 Allen head bolts.
- B.** First place the Top into its appropriate position on the sides assembly.
- C.** Insert the 1-3/8" Allen head bolts first through holes in the blocks on the inside edge of the Top then into the threaded inserts in the Side Panels (Figure 4A). Tighten all screws with Allen wrench.

STEP 5 Assembly of Top Molding

THIS STEP REQUIRES:
TOP MOLDING (B)



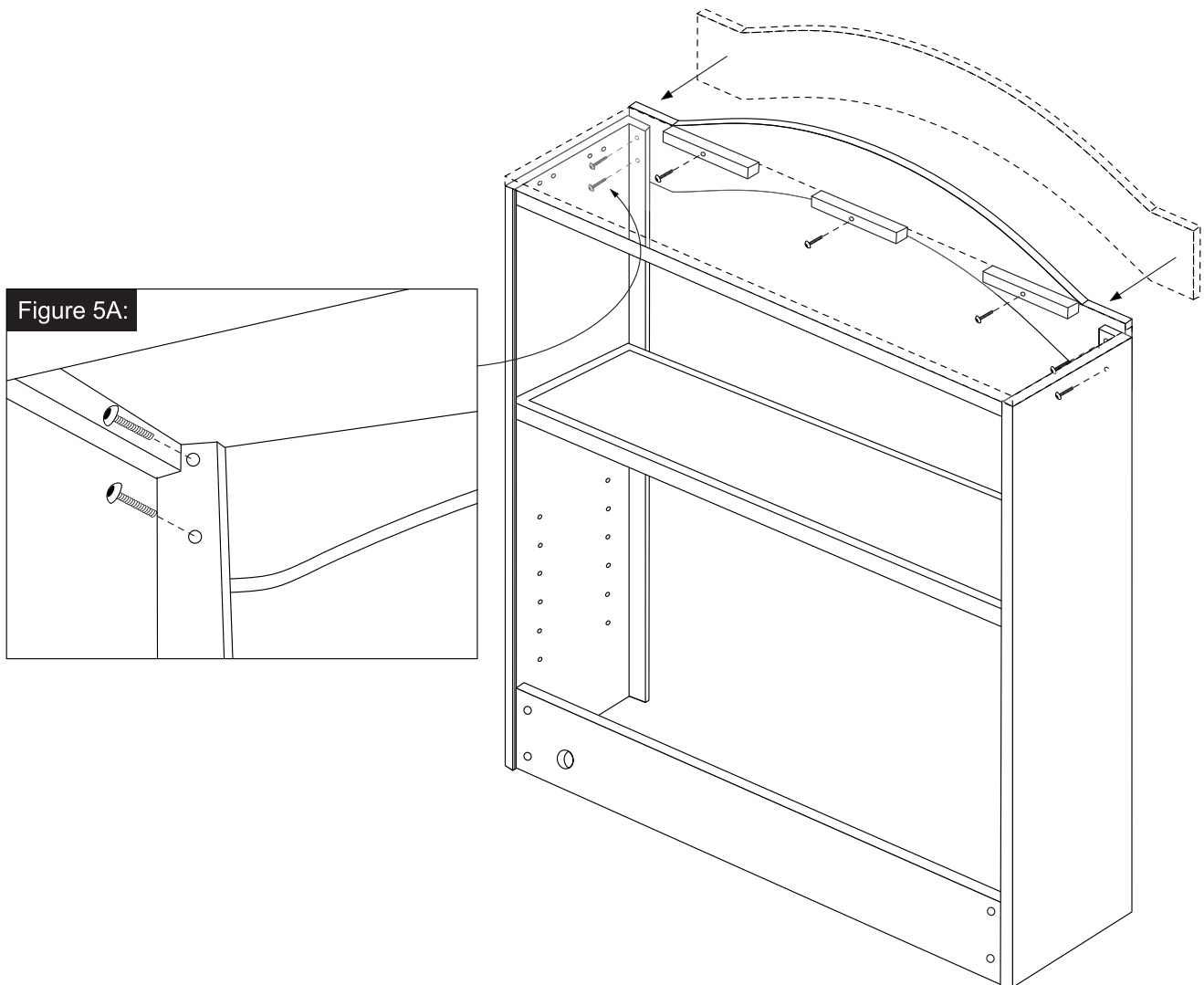
(7) Allen head Bolt 1-3/8" (H)



(1) Allen wrench (N)

Figure 5:

Model shown is example only.
Styles may vary



Attach the Top Molding to the Side Panels & front / back rails (Top) using 4 Allen head bolts.

Insert the 1-3/8" Allen head bolts first through inside edge of side Panels & front / back rails (Top), then through the threaded inserts in the Top (Fig. 5 & 5A). Tighten with Allen wrench.

STEP 6 Assembly of Back Panel

THIS STEP REQUIRES:

(2) BACK PANEL (G)

(26) Wood Screw 3/4" (I)

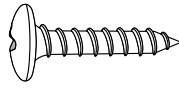
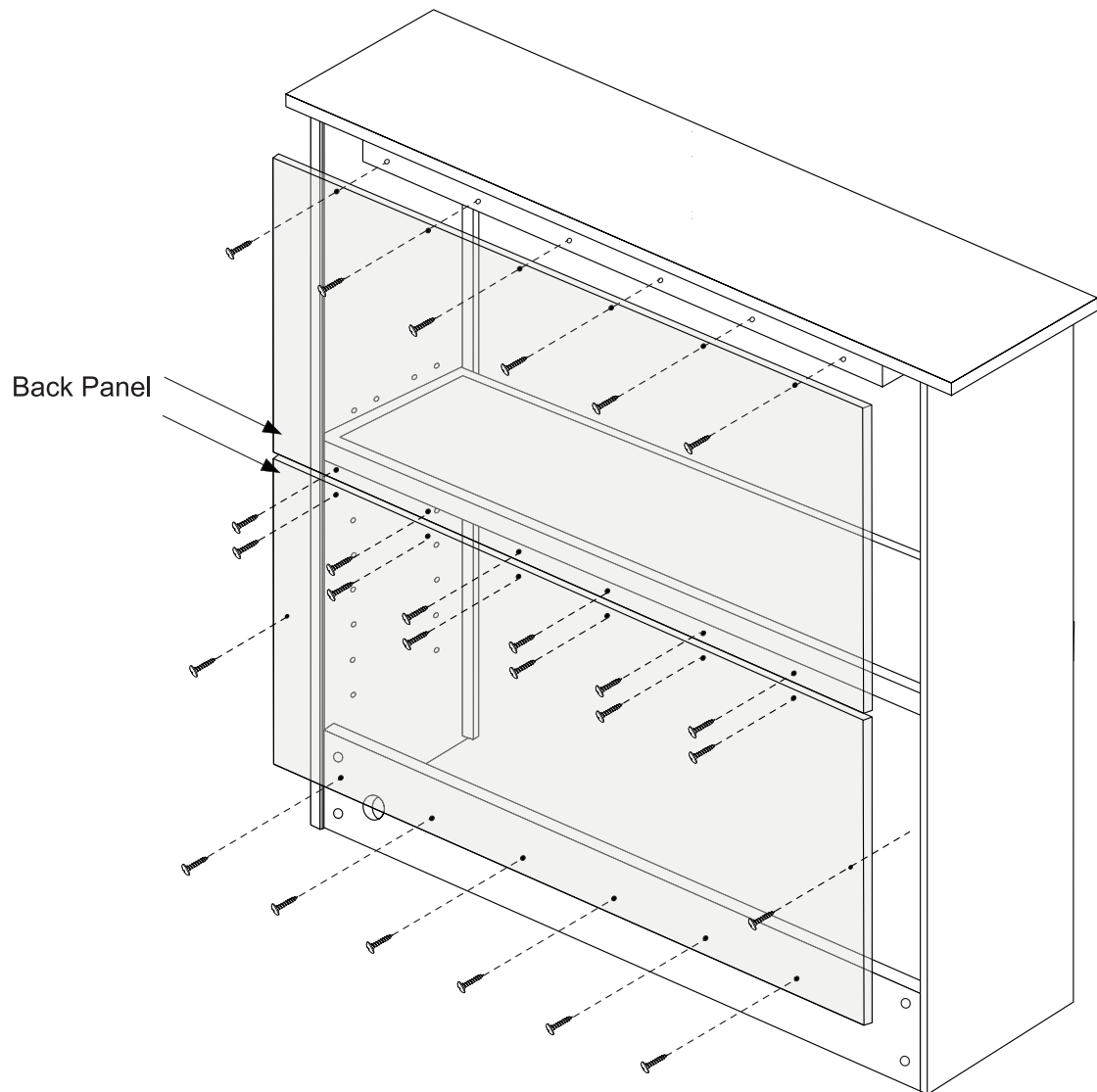


Figure 6:

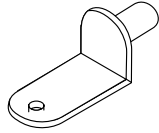
Model shown is example only.
Styles may vary



Attach the Back Panel to the back of the Hutch using the Wood Screws as shown in figure 6.

STEP 7 Assembly of Adjustable Shelf

THIS STEP REQUIRES:
ADJUSTABLE SHELF (D)



(4) Shelf Pegs (L)

(4) Philips head screws 1/2"(M)

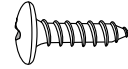


Figure 7:

Model shown is example only.
Styles may vary

- A.** According to your need, choose a desired shelf height position and insert the shelf pegs as shown in Fig. 7A.
- B.** Put the adjustable shelf onto the shelf pegs.
- C.** Secure the adjustable shelf using Philips head screws as shown in Fig. 7B.

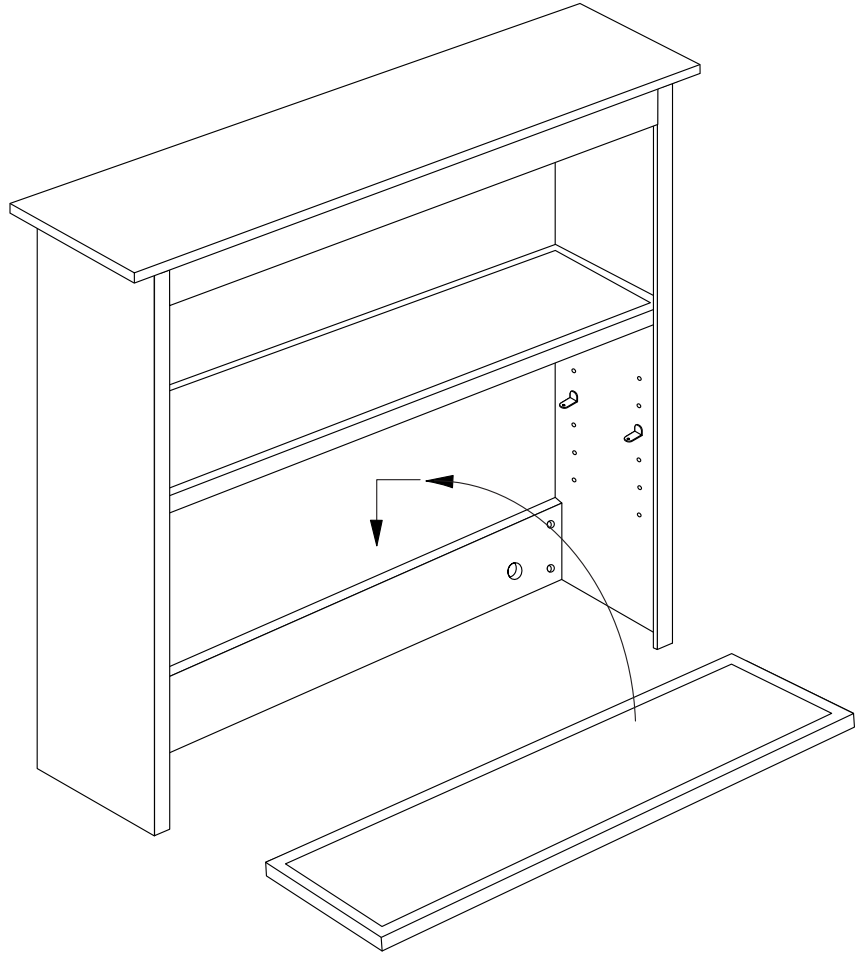


Figure 7A:

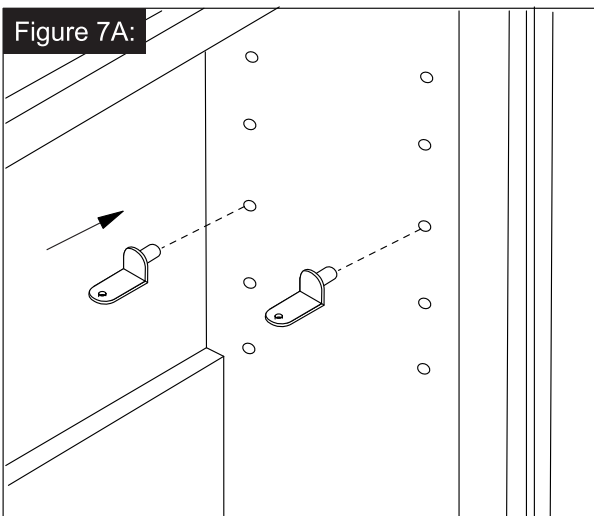
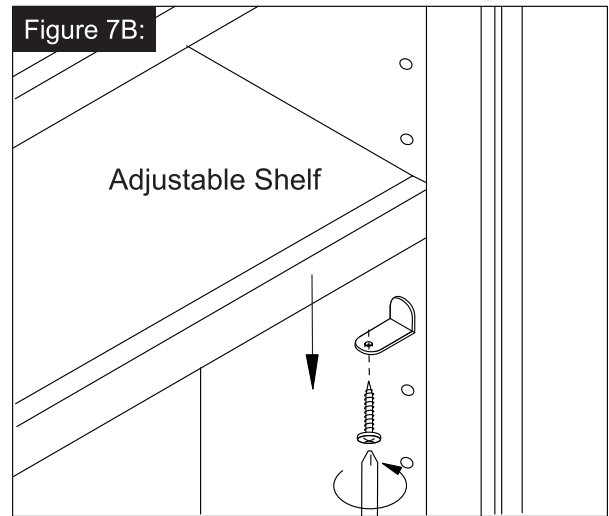


Figure 7B:



STEP 8 Attach the Hutch to the combo

THIS STEP REQUIRES:

(2) Mounting Screws
(From Galley Rail Hardware)

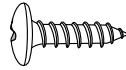
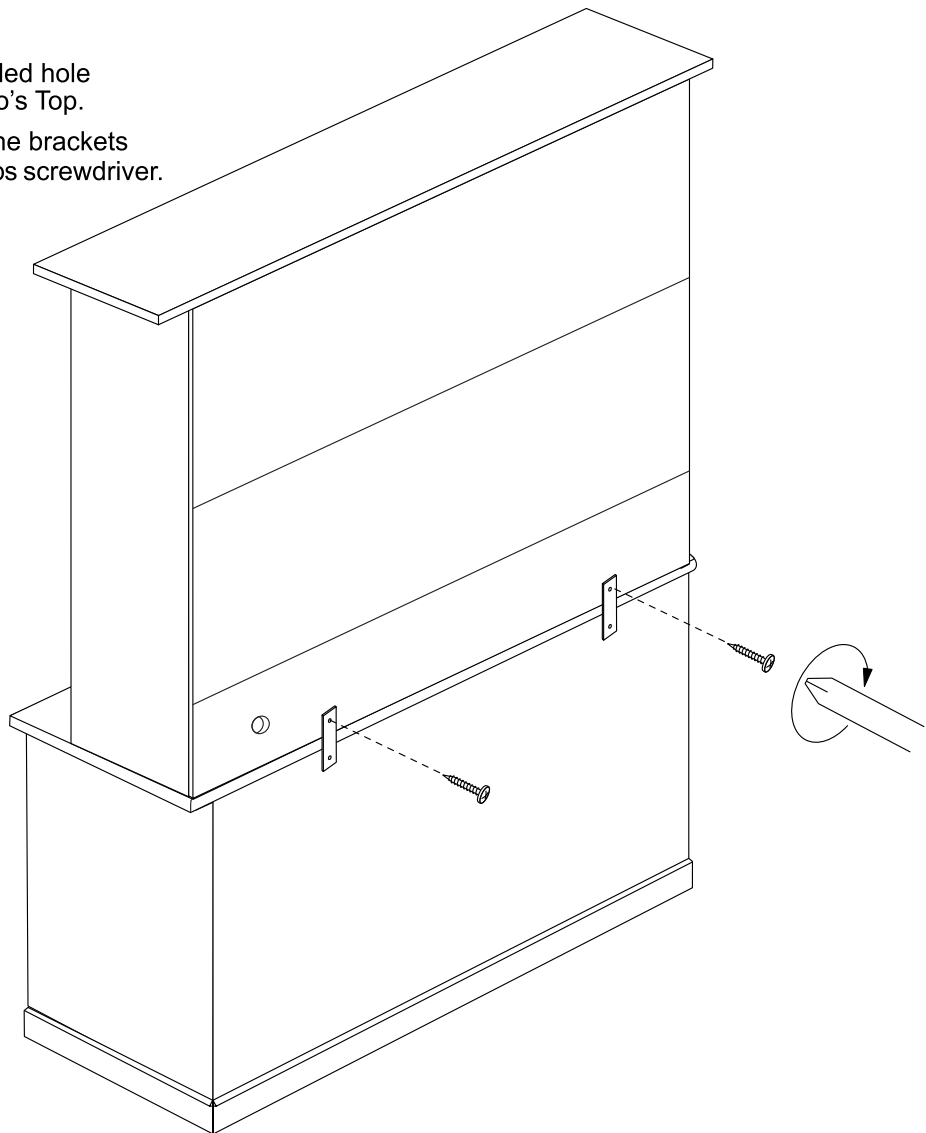


Figure 8:

Model shown is example only.
Styles may vary

IMPORTANT: If the Galley Rail is attached, please remove prior to placing the Hutch on the Combo.

- A. Place the Hutch onto the Top of the combo.
- B. Align brackets over the pre-drilled hole on the rear edge of the Combo's Top.
- C. Screw one screw per hole in the brackets into pre-drilled hole using Philips screwdriver.





257 Prospect Plains Road
Cranbury, NJ 08512
Phone: 888-266-2848, 609-409-2495
Fax: 609-409-5809